

ASM 14-4, 14-6, 14-9, 14-12, 14-6-PC, 14-9-PC, 14-12-PC

## Repair instructions





## Contents

- 1. Models described**
- 2. Technical data**
- 3. Notes / requirements**
- 4. Tools required**
- 5. Lubricants and auxiliary substances required**
- 6. Disassembly**
- 7. Assembly**
- 8. Troubleshooting**
- 9. Connection diagram**



## 1. Models described

These instructions describe how to repair the following models:

Model	Order no.
ASM 14-4	7 112 27 00 95 0
ASM 14-6	7 112 28 00 95 0
ASM 14-9	7 112 31 00 95 0
ASM 14-12	7 112 57 00 95 0
ASM 14-6-PC	7 112 54 00 95 0
ASM 14-9-PC	7 112 55 00 95 0
ASM 14-12-PC	7 112 56 00 95 0



## 2. Technical data

### Technical data

The complete technical data can be found in the operating instructions for the model.

### Test data

Up-to-date test data for all models can be found on the FEIN Extranet (Customer Service → Repair Guides).

### Lubricants

The lubricants and container sizes available from FEIN can be found on the FEIN Extranet (Customer Service → Repair Guides).

### Lists of spare parts

Lists of spare parts and exploded views are available online at [www.fein.com](http://www.fein.com)



## 3. Notes / requirements

### Note

These instructions are only intended for persons with suitable technical training. It is assumed that the reader has mechanical and electrical training.

**Only use original FEIN spare parts!**

### Requirements

Please note that power tools may only be repaired, maintained and checked by a trained electrician, as improper repair can result in serious risks to the user.

The provisions set out in *DIN VDE 0701-0702* should be observed after repairs.

The relevant accident prevention regulations of the employers' liability insurance associations are to be observed when commissioning.

The German Equipment and Product Safety Act applies for correct use.

**Outside Germany, the regulations applicable in the relevant country must be observed!**



## 4. Tools required

### Standard tools

- Vice
- Torx 10 screwdriver
- Slotted screwdriver: 0.6x3.5
- Slotted screwdriver: 7.0x100
- Circlip pliers: opener / straight, 18-60 mm
- Circlip pliers: opener / stepped, 3-10 mm
- Socket head wrench: WAF 2.5 mm
- Snap ring pliers
- Bar magnet
- Forceps
- Feeler gauge
- Side-cutting pliers
- Soldering station

### Special tool

- Torque wrench 3 21 23 002 00 6

### NOTE

You can only order special tools with an order number from FEIN.



## 5. Lubricants and auxiliary substances required

### Lubricants

Grease	3 21 600 1423 0	0.6 g	Fill taper of tool holder with grease Apply grease to ball seats Apply approx. 1 g to needle bearing bush
--------	-----------------	-------	---

### Auxiliary substances

Loctite 270	0 90 006 0010 9	50 ml	Secure screws
-------------	-----------------	-------	---------------



## 6. Disassembly

### Removing the motor housing



1. Remove the coded sleeve (1).
2. Unscrew the nine screws (2) from the motor housing.
3. Spread open the motor housing (3) and remove the housing cover.
4. Remove the pressure piece (4).

Tools:

- Slotted screwdriver 0.6x3.5
- Circlip pliers
- Torx 10 screwdriver





## 6. Disassembly

### Removing the motor housing

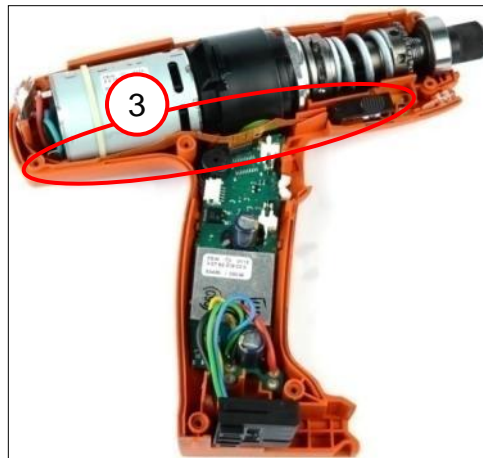

1. Remove the slide switch with pressure spring (1) and the pushbutton with pressure spring (2).
2. Carefully pull out the foil conductor (3) and carefully remove from the motor housing.



## 6. Disassembly

### Removing the motor housing

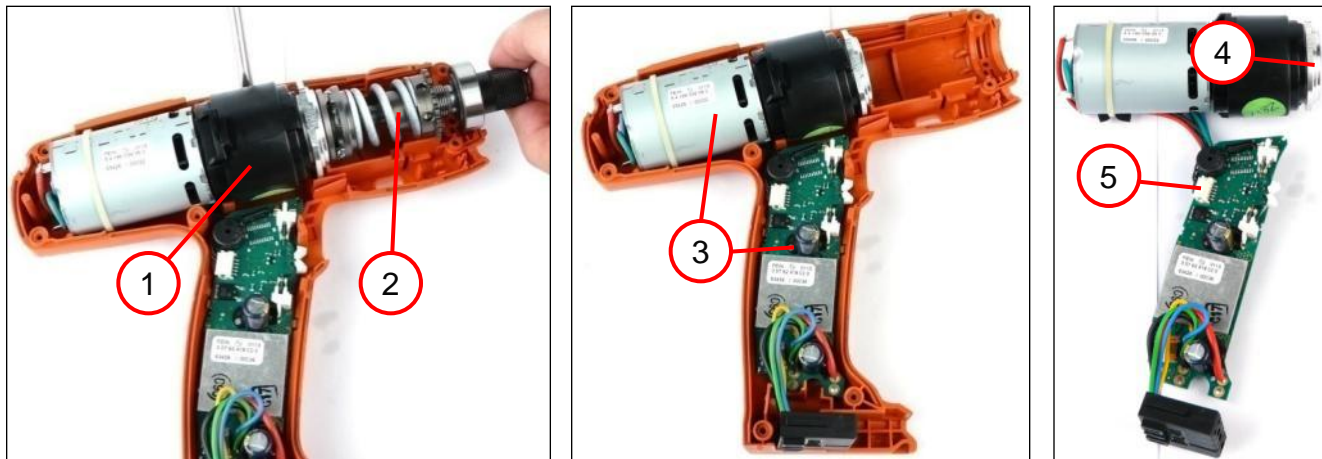

1. At the same time, lift the gearbox (1) and the tool holder (2).
2. Pull the clutch (2) off the planetary gear.
3. Remove the motor with the electronics (3) from the motor housing.
4. Pull the bush (4) off the planetary gear.
5. Pull off the plug (5).

#### Tools:

- Slotted screwdriver  
7.0x125



## 6. Disassembly

### Removing the motor housing

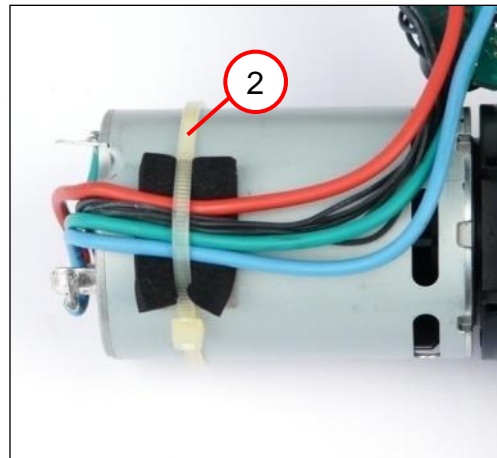
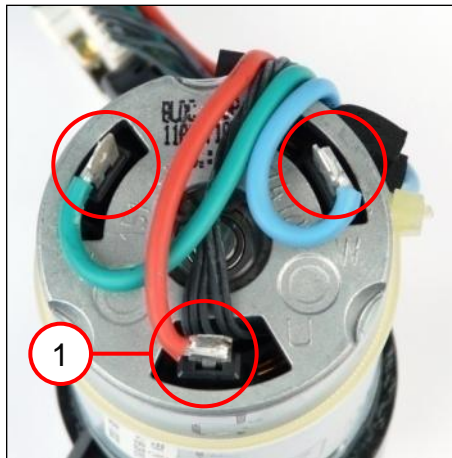

1. With a soldering rod, remove the connection cable from the motor connections (1).
2. With side-cutting pliers, remove the cable tie (2).

Tools:

- Soldering rod
- Side-cutting pliers



## 6. Disassembly

### Removing the motor



### NOTE

There is a risk that parts may fall out of the planetary gear when it is pulled out. The photo shows the construction of the planetary gear.



## 6. Disassembly

### Removing the motor

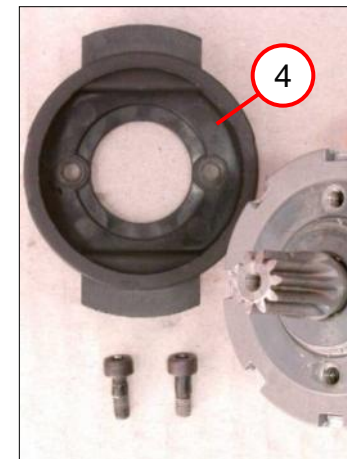
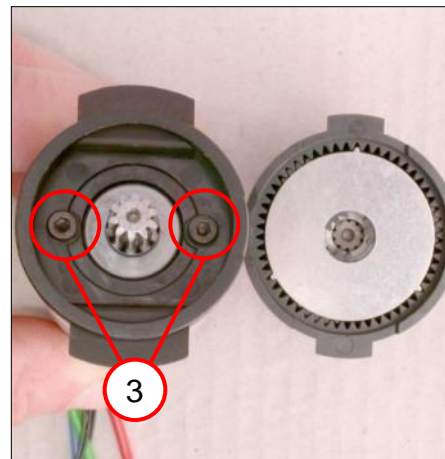
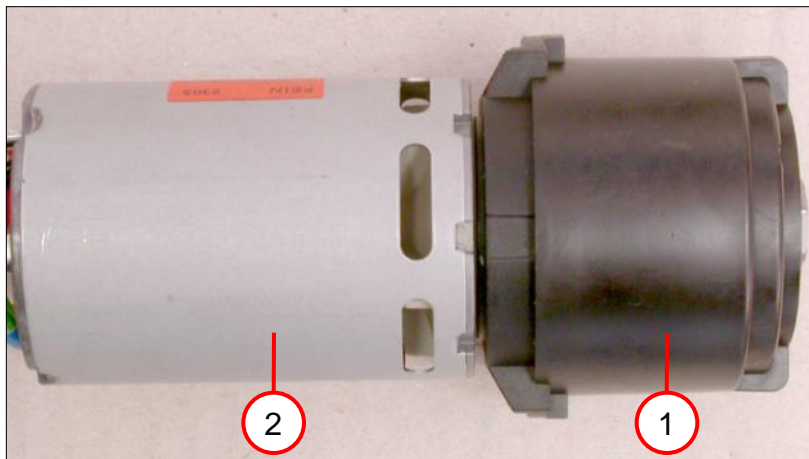

1. Pull the gearbox (1) off the EC motor (2).  
☞ Please note information on page 12!
2. Unscrew the screws (3) and remove the motor flange (4).

Tools:

- Socket head wrench:  
WAF 2.5 mm



## 6. Disassembly

### Removing the tool holder

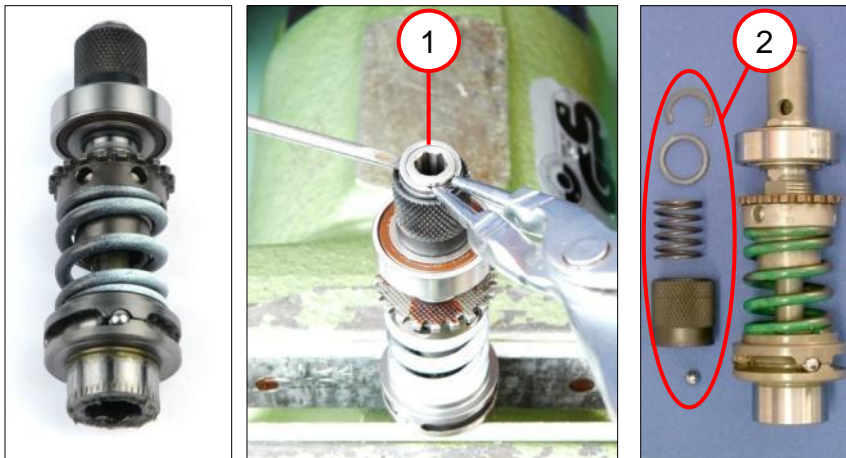

1. Press the circlip (1) off the tool holder.
2. Remove parts (2) of the tool locking device.
  - ☞ Circlip; ring; pressure spring; sleeve; ball > D=4 mm.

#### Tools:

- Circlip pliers:  
opener / stepped 3-10 mm
- Slotted screwdriver



## 6. Disassembly

### Removing the clutch

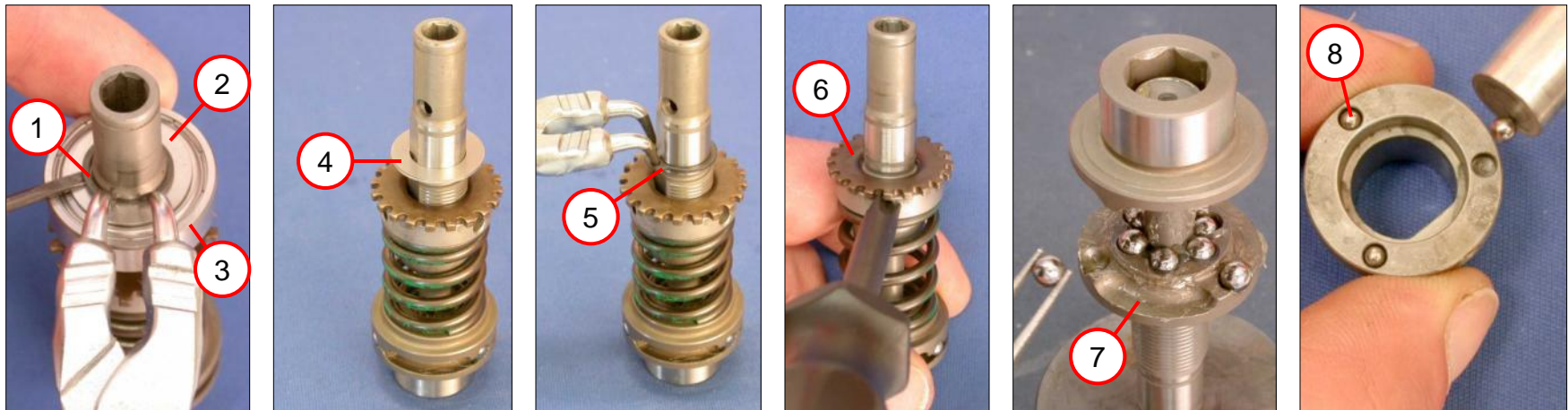

1. Remove the circlip (1).
2. Remove the discs (2) and the grooved ball bearing (3).
3. Remove the discs (4) and the circlip (5).
4. Unscrew the adjusting ring (6).  
 ☞ The adjusting ring has a left-handed thread.
5. Remove the nine balls from the clutch ring (7).
6. Remove the three balls from the ring (8).

Tools:

- Circlip pliers  
 opener / stepped, 3-10 mm
- Torque wrench
- Bar magnet



## 6. Disassembly

### Removing the cover

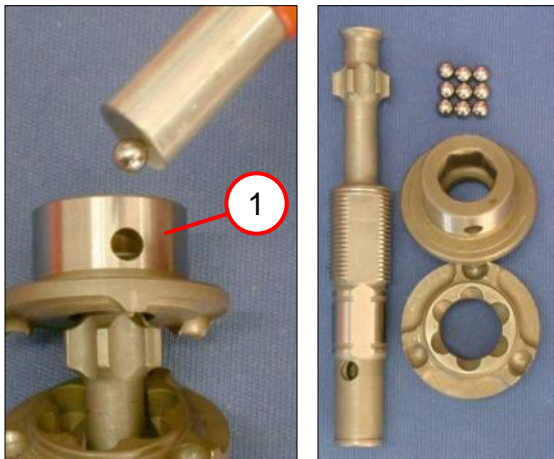

1. Remove the nine balls from the clutch ring (1) and tool holder.

#### **NOTE**

Degreasing the clutch ring before disassembly makes it easier to remove the balls.

Tools:

- Bar magnet



ASM 14-4, 14-6, 14-9, 14-12, 14-6-PC, 14-9-PC, 14-12-PC

## 7. Assembly





## 7. Assembly

### Fitting the clutch

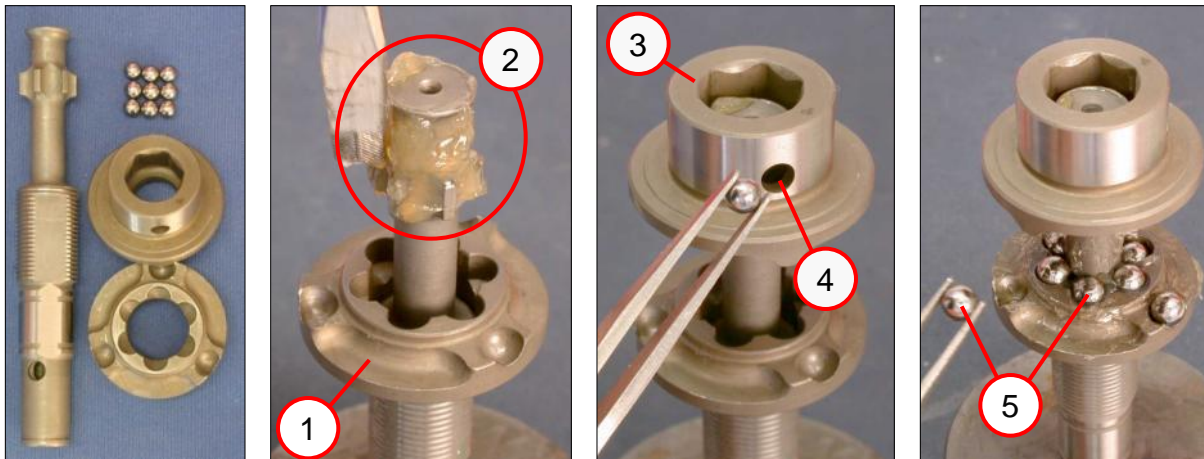

1. Insert the lower clutch ring (1) in the correct position.
2. Apply grease (3 21 60 014 23 0) generously to the end of the tool holder (2).
3. Position the top clutch ring (3).
4. Insert the nine balls D=4 mm through the hole (4).
5. Insert nine balls D=5 mm (5) into the lower clutch ring.

Tools:

- Slotted screwdriver:  
7.0x125
- Grease (3 21 60 014 23 0)
- Forceps



## 7. Assembly

### Fitting the clutch

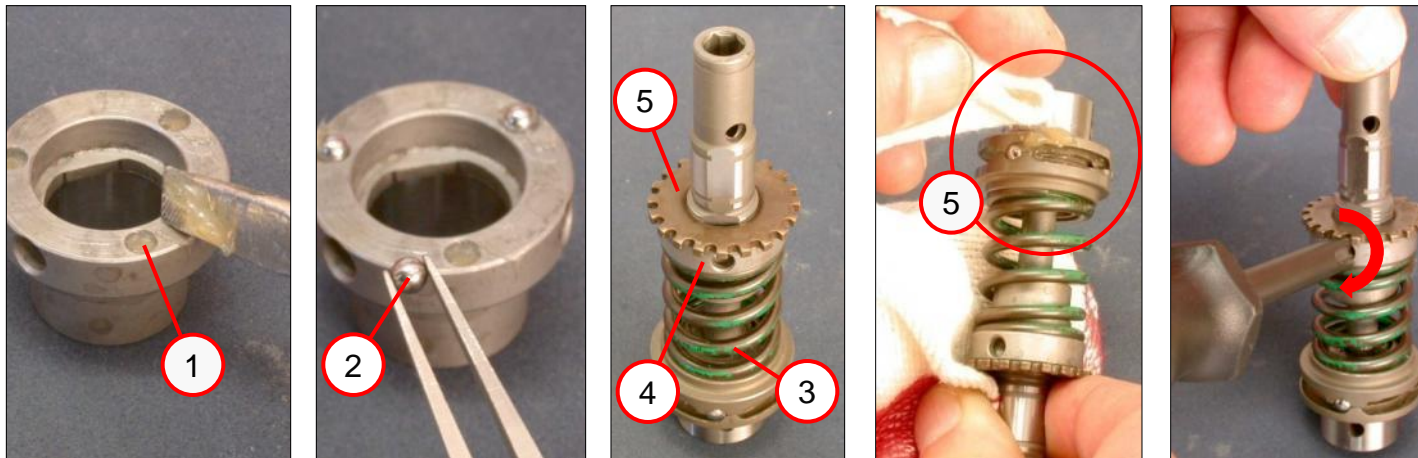

1. Fill the hole (1) in the ring with grease (3 21 60 014 23 0).
2. Insert the three balls [D=3 mm] (2) in the holes.
3. Fit the pressure spring (3), the ring (4) and the adjusting ring (5) on the pre-fitted tool holder.
4. Remove excess grease (5).
5. Screw in the adjusting ring by approx. 10 mm.  
 ⚙ The adjusting ring has a left-handed thread.

#### Tools:

- Forceps
- Grease (3 21 60 014 23 0)
- Torque wrench



## 7. Assembly

### Fitting the tool holder

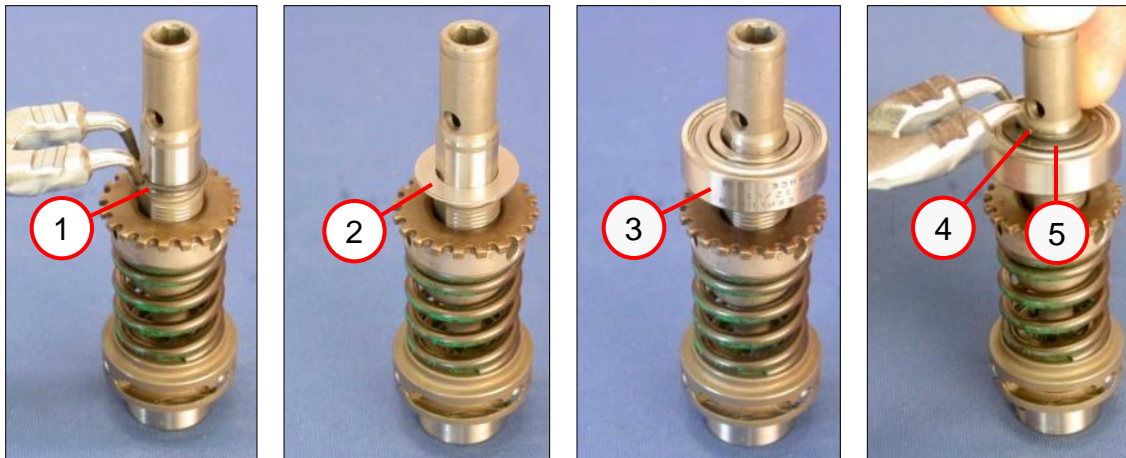

1. Fit the circlip (1) on the tool holder.
2. Fit the discs (2) on the tool holder.  
☞ Basic setting = 0.8 mm
3. Fit the grooved ball bearing (3) on the tool holder.
4. Fit the discs (4) and the circlip (5).

Tools:

- Circlip pliers:  
opener / stepped 3-10 mm



## 7. Assembly

### Fitting the tool holder

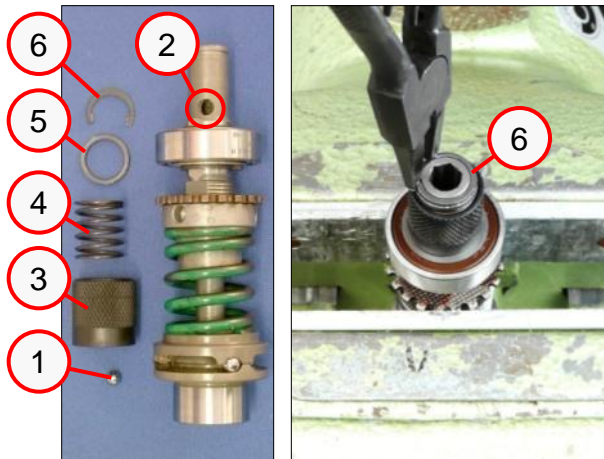

1. Insert the ball (1) in the hole (2).
2. Slide the sleeve (3) over the tool holder.
3. Insert the spring (4) in the sleeve.
4. Place the ring (5) on the sleeve and press down.
5. Fit the snap ring (6).

Tools:

- Vice
- Snap ring pliers



## 7. Assembly

### Fitting the planetary gear

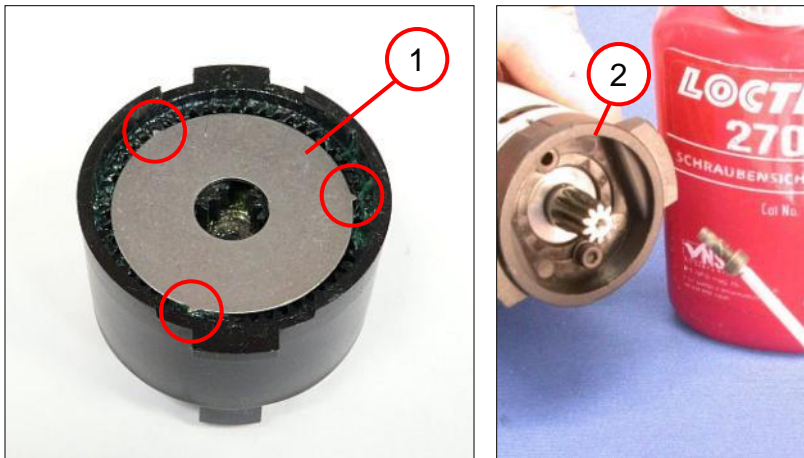

1. Insert the circlip (1) into the gearbox so that it is flush.
  - ☞ Ensure that the circlip does not slip during assembly.
  - ☞ The three prongs on the circlip must lie snugly inside the teeth.
2. Screw on the motor flange (2).
  - ☞ Tighten the cylinder head screw to  $1\text{Nm} \pm 0.1\text{Nm}$  and secure with Loctite.

Tools:

- Loctite 270
- Socket wrench: WAF 2.5



## 7. Assembly

### Fitting electronics

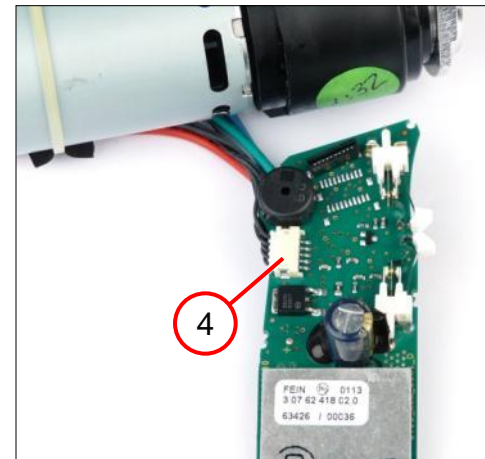
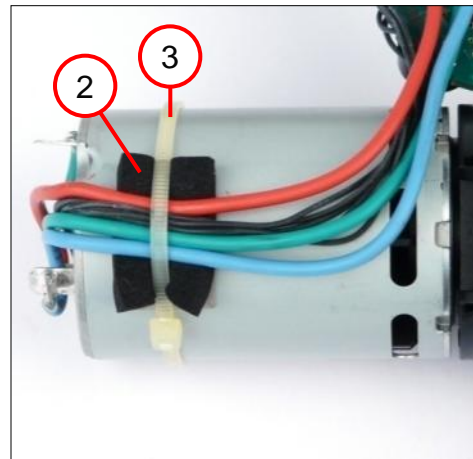
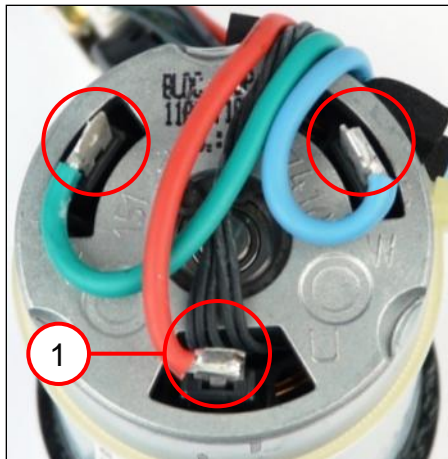

1. Securely solder the wires (1) to the motor as shown.
  - ☞ Refer to the electronics circuit diagram for the correct way to connect them.
2. Fix the cables with the padding (2) and a cable tie (3).
  - ☞ This step is not absolutely necessary, but it does make the rest of the assembly process easier.
3. Connect the plug (4) from the motor to the electronics.

Tools:  
- Soldering station



## 7. Assembly

### Fitting the planetary gear

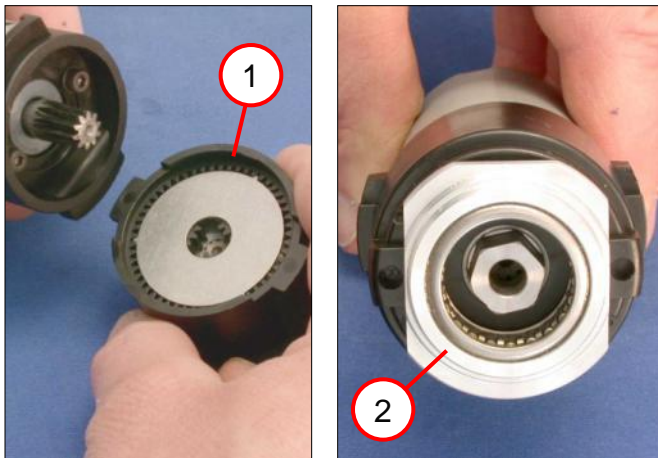

1. Join the planetary gear (1) to the motor.
  - ☞ The thrust washer must be fixed in the tothing of the gearbox housing.
  - ☞ If the thrust washer changes position, a scratching noise will be heard during operation.
2. Grease the bush (2) (grease 3 21 600 1423 0) and position it on the planetary gear.
  - ☞ Note the installation position. The curve of the bush should face the switch.

Tools:

- Grease (3 21 60 014 23 0)





## 7. Assembly

### Fitting the motor and clutch

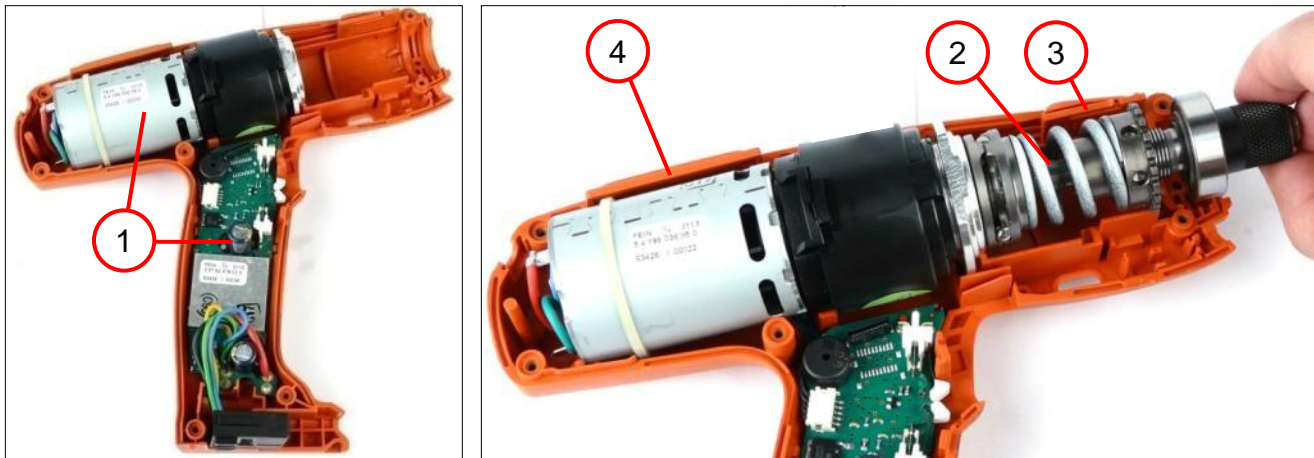

1. Insert the electronics with the motor (1) into the motor housing.  
☞ Insert the flange such that the curved side faces down towards the operating side.
2. Insert the clutch (2).
3. Fit the cover (3).
4. Fit the housing insert (4).



## 7. Assembly

### Fitting the foil conductor

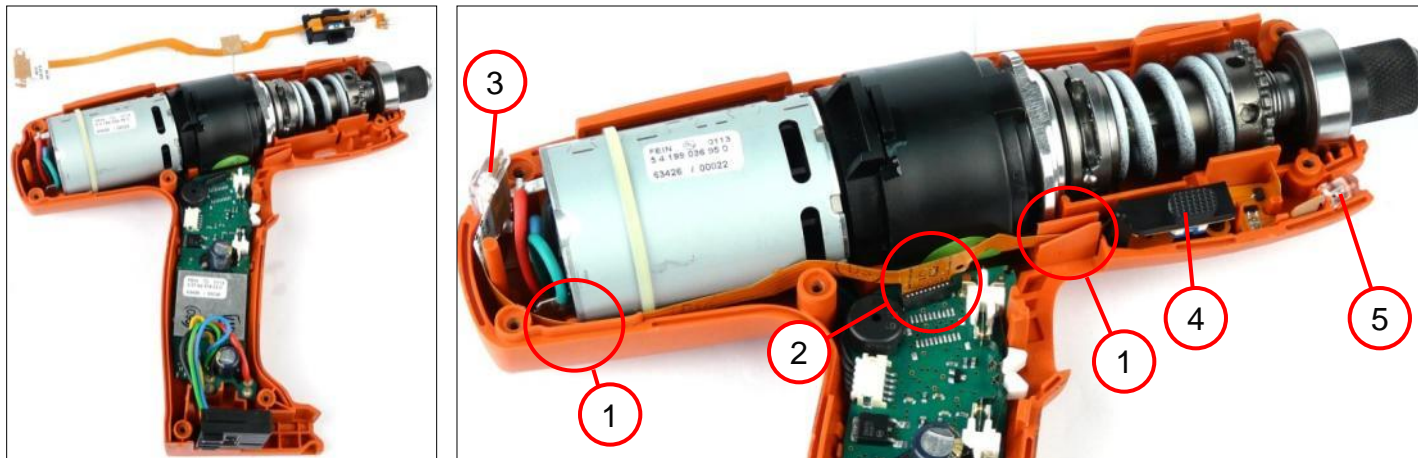

1. Route the foil conductor as shown in the photo.
  - ☞ Insert the foil conductor in the guide (1).
2. Connect the foil conductor to the electronics (2).
3. Insert the LED indicator (3) in the recess provided.
4. Insert the pushbutton (4).
5. Insert the LED (5).



## 7. Assembly

### Fitting the slide switch

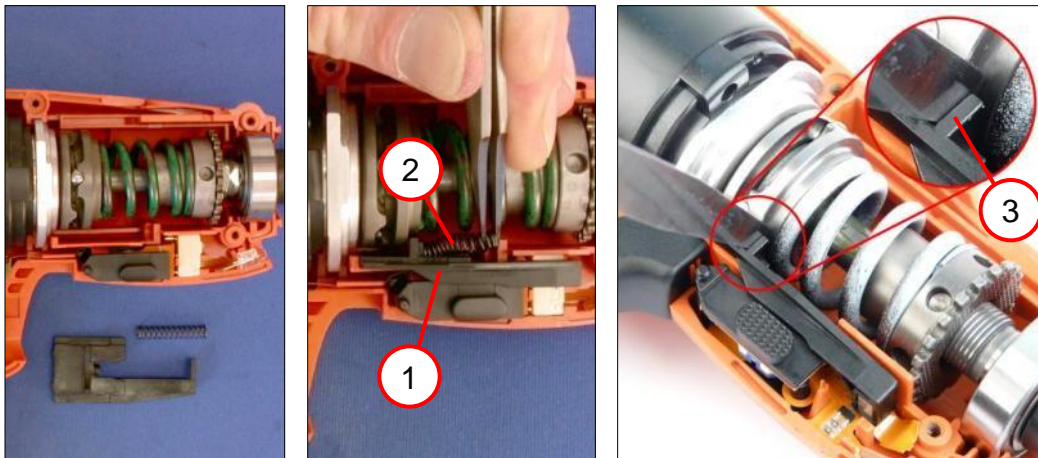

1. Insert the slide switch (1) in the housing.
2. Insert the spiral spring (2).
3. Check the play (3) between the slide switch and switch ring.
  - ☞ The installation dimension is  $0.7 \pm 0.3$  mm.
  - ☞ The installation dimension can be adjusted by adding or removing discs in front of and behind the grooved ball bearing on the tool holder.

Tools:

- Forceps
- Feeler gauge



## 7. Assembly

### Fitting the cover



1. Insert the pressure spring (2) and the pushbutton (1).
2. Insert the pressure piece (3).
3. Fit the housing cover on the machine.
  - ☞ When placing the housing cover in position, make sure the electronics film is not damaged.



## 7. Assembly

### Fitting the cover



1. Screw down the housing cover.  
☞ Tighten the screws to 1.2 Nm <sup>-0.1Nm</sup>.
2. Manually press down the coded sleeve (1).

Tools:

- Torx 10 screwdriver



## 8. Troubleshooting

**See separate file on Extranet or retail partner portal.**

ASM 14-4, 14-6, 14-9, 14-12, 14-6-PC, 14-9-PC, 14-12-PC

## 9. Connection diagram

