



ASCD 18-W2



ASCD 18-W4





Contents

- 1. Models described**
- 2. Technical data**
- 3. Notes and requirements**
- 4. Tools required**
- 5. Lubricants and auxiliary substances required**
- 6. Disassembly**
- 7. Assembly**
- 8. Troubleshooting**
- 9. Connection diagram**



1. Models described

These instructions describe how to repair the following models:

Model	Order number
ASCD 18-W2	7 115 01 00 94 0
ASCD 18-W4	7 115 02 00 94 0



2. Technical data

Technical data

The complete technical data can be found in the operating instructions for the model.

Test data

Up-to-date test data for all models can be found on the FEIN Extranet (Customer Service → Repair Guides).

Lubricants

The lubricants and container sizes available from FEIN can be found on the FEIN Extranet (Customer Service → Repair Guides).

Lists of spare parts

Lists of spare parts and exploded views are available online at www.fein.com



3. Notes and requirements

Note

These instructions are only intended for persons with suitable technical training. It is assumed that the reader has mechanical and electrical training.

Only use original FEIN spare parts!

Provisions

Please note that power tools may only be repaired, maintained and checked by a trained electrician, as improper repair can result in serious risks to the user.

The provisions set out in **DIN VDE 0701-0702** should be observed after repairs.

The relevant accident prevention regulations of the employers' liability insurance associations are to be observed when commissioning.

The German Equipment and Product Safety Act applies for correct use.

Outside Germany, the regulations applicable in the relevant country must be observed!



4. Tools required

Standard tools

- Torx T10
- Cross-tip screwdriver
- Slotted screwdriver
- Slotted screwdriver (small)
- Circlip pliers (angled)
- Soldering rod
- Torque wrench

Special tool

- Assembly aid 6 41 22 121 01 0
- Sleeve and taper 6 41 22 125 01 0



5. Lubricants and auxiliary substances required

Lubricants

Grease	0 40 101 0100 4	4 g	Tool holder
Grease	0 40 119 0500 7	1g	Tool holder



6. Disassembly

Disassembling motor housing

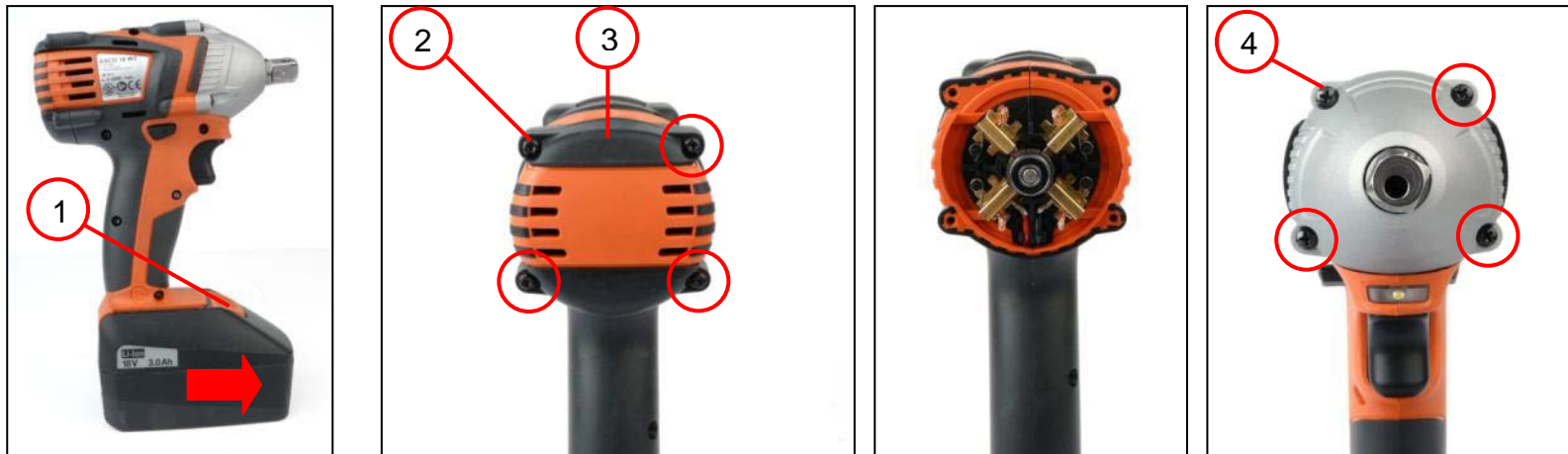

1. Press catch (1) and pull battery off tool.
2. Loosen four screws (2) and take off with cover (3).
3. Unscrew the four screws (4).

Tool:

- Torx T10
- Cross-tip screwdriver



6. Disassembly

Disassembling motor housing

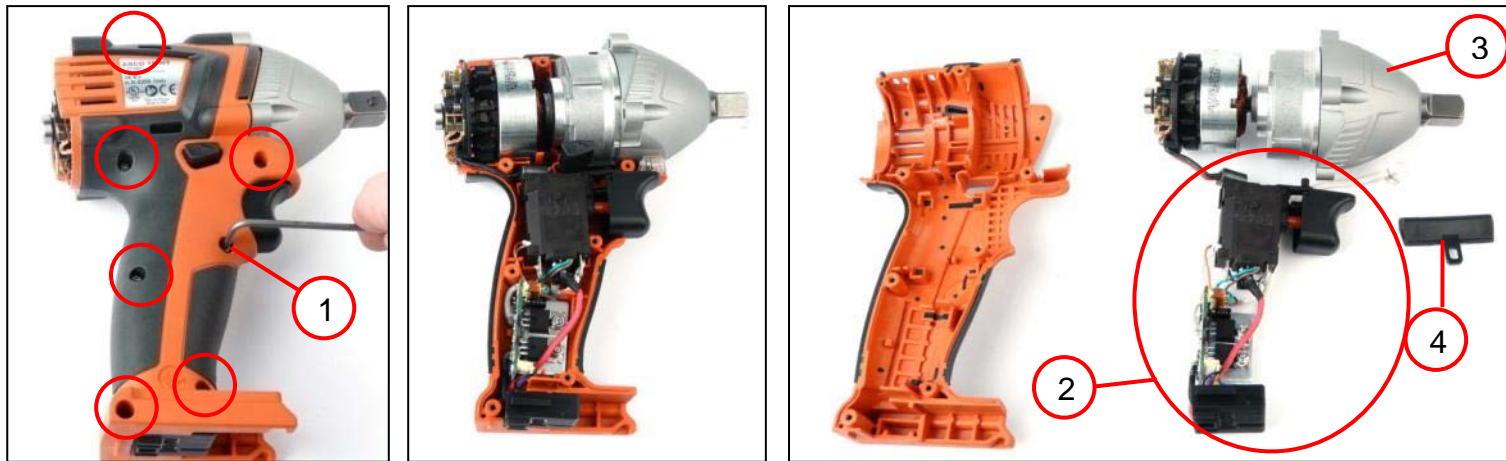

1. Unscrew the seven screws (1) and take off motor housing.
2. Remove switch (2), gearbox (3) and toggle switch (4) from motor housing.

Tool:

- Torx T10



6. Disassembly

Disassembling motor housing

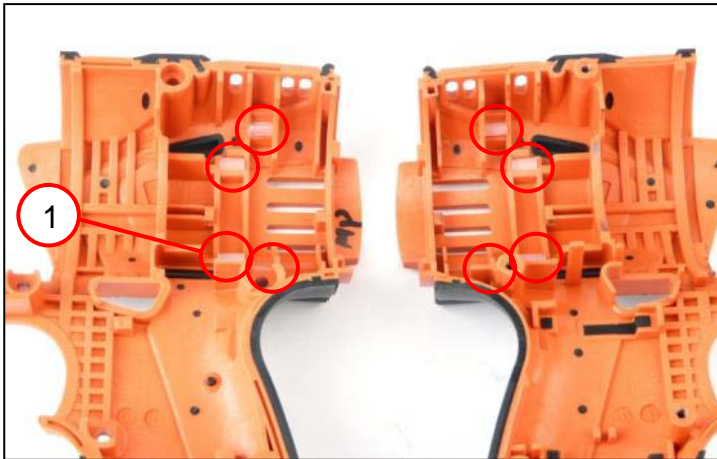

1. Remove the eight pressure pieces (1) from the motor housing halves.



6. Disassembly

Disassembling tool holder (applies to: ASCD 18-W4)

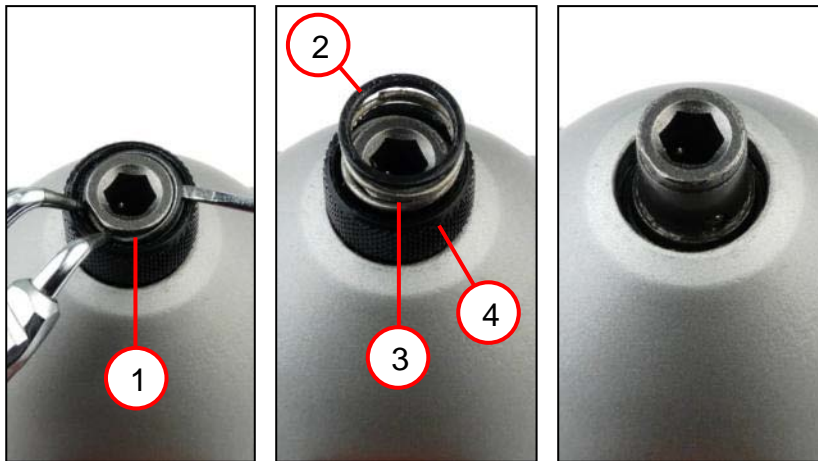

1. Remove circlip (1).
2. Remove disc (2), spring (3) and sleeve (3).

Tool:

- Circlip pliers (angled)
- Slotted screwdriver (small)



6. Disassembly

Disassembling the gearbox

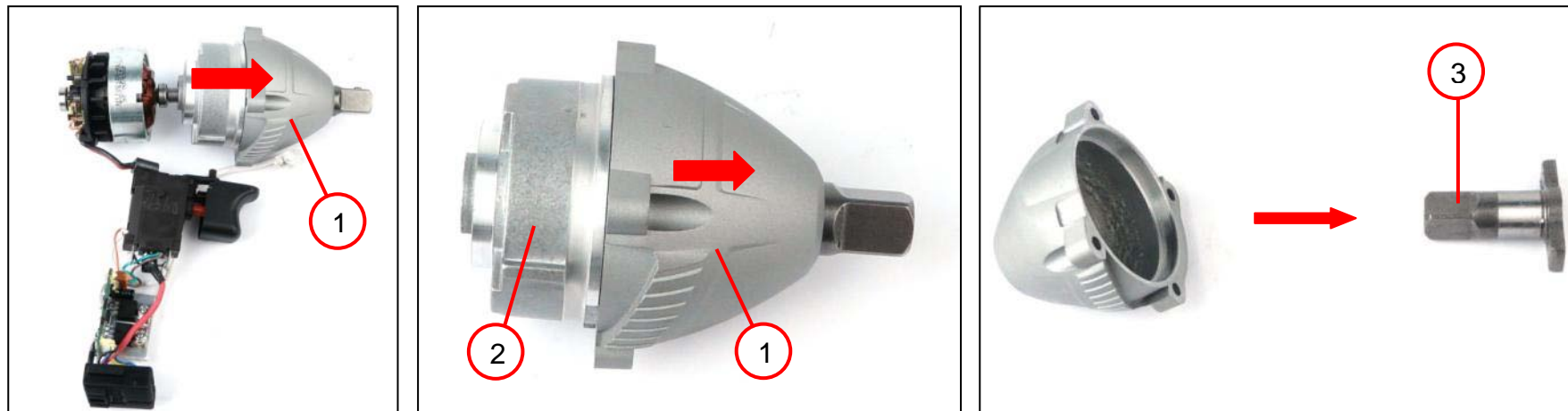

1. Pull gearbox and gearbox housing (1) off armature.
2. Pull gearbox housing (1) off gearbox (2) and remove tool holder (3).

NOTE

Alternatively the gearbox can be removed without opening the motor housing. by loosening the four screws on the gearbox housing. The gearbox can then be pulled out of the motor housing.



6. Disassembly

Disassembling gearbox housing

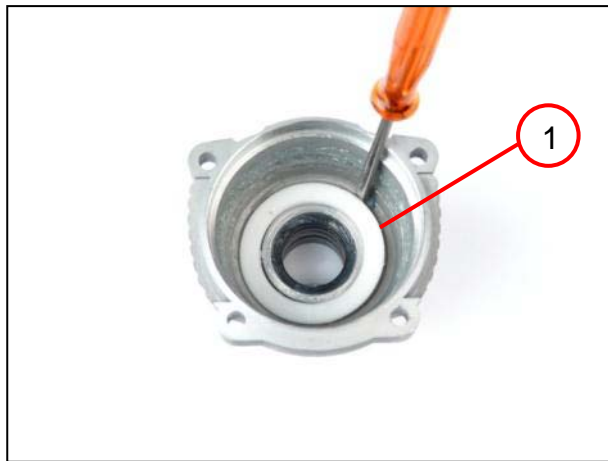

1. Remove disc (1) from housing with a slotted screwdriver.

Tool:

- Slotted screwdriver



6. Disassembly

Disassembling brush holder set

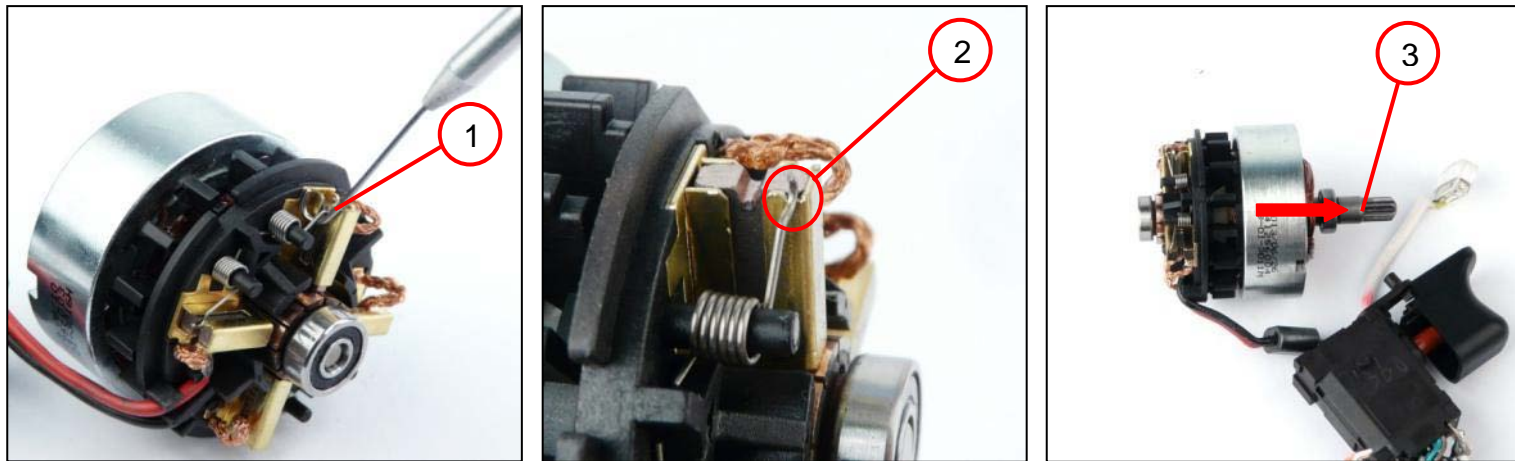

1. Lift four tension springs (1) of brush holder on to notches provided (2).
2. Pull armature (3) off brush holder set.

Tool:

- Assembly aid



6. Disassembly

Disassembling switch

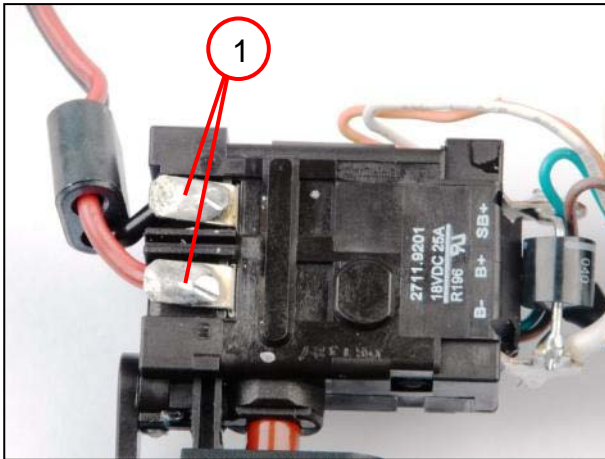

1. Unsolder the two cables (1) from switch.

Tool:

- Soldering rod



6. Disassembly

Disassembling motor

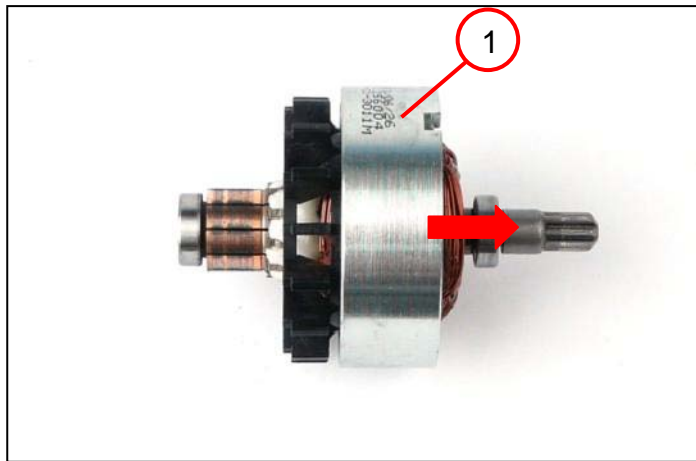

1. Pull stator (1) off armature.

Caution!

Risk of crushing due to strong pull of magnet!

☞ During assembly/disassembly, only touch magnet on outer race.



7. Assembly

Assembling gearbox housing



1. Insert disc (1) into gearbox housing.

NOTE

Curve of disc must face down.

2. Insert ball (2) into tool holder.
3. Slide tool holder (3) into gearbox housing.
4. Coat inside (4) of tool holder with 1g of grease.

Tool:

- Grease
(0 40 119 0500 7)



7. Assembly

Assembling gearbox housing

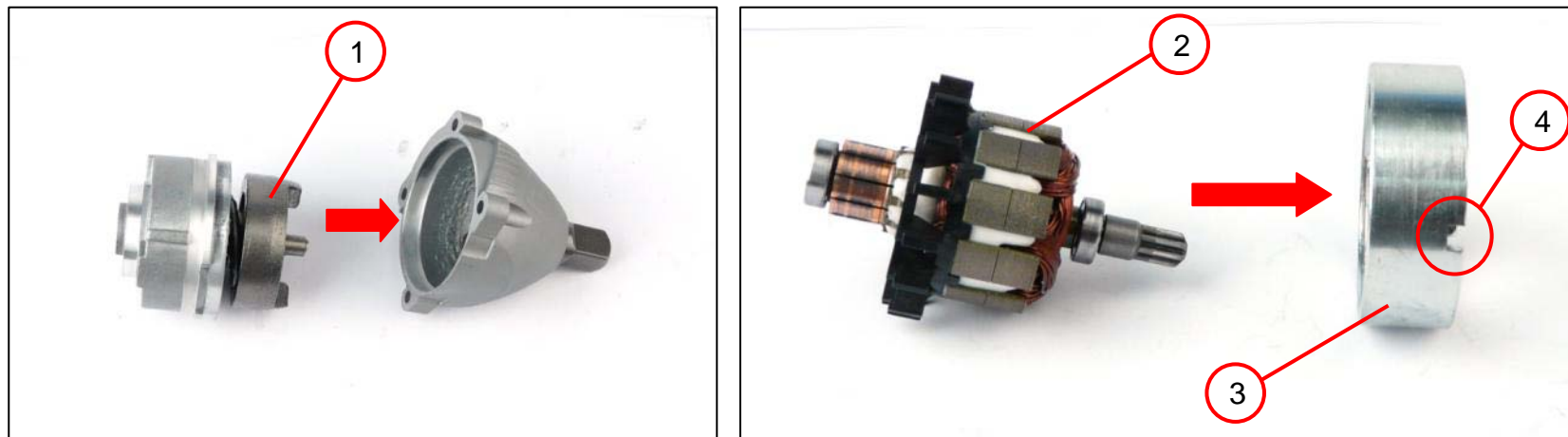

1. Coat gearbox (1) with 4g of grease and insert into gearbox housing.
2. Slide armature (2) into stator (3).
 - ☞ The recess (4) must face right as shown.

Caution

Risk of crushing due to strong pull of magnet.
 During assembly/disassembly, only touch magnet on outer race.

Tool:

- Grease
 (0 40 101 0100 4)



7. Assembly

Assembling gearbox

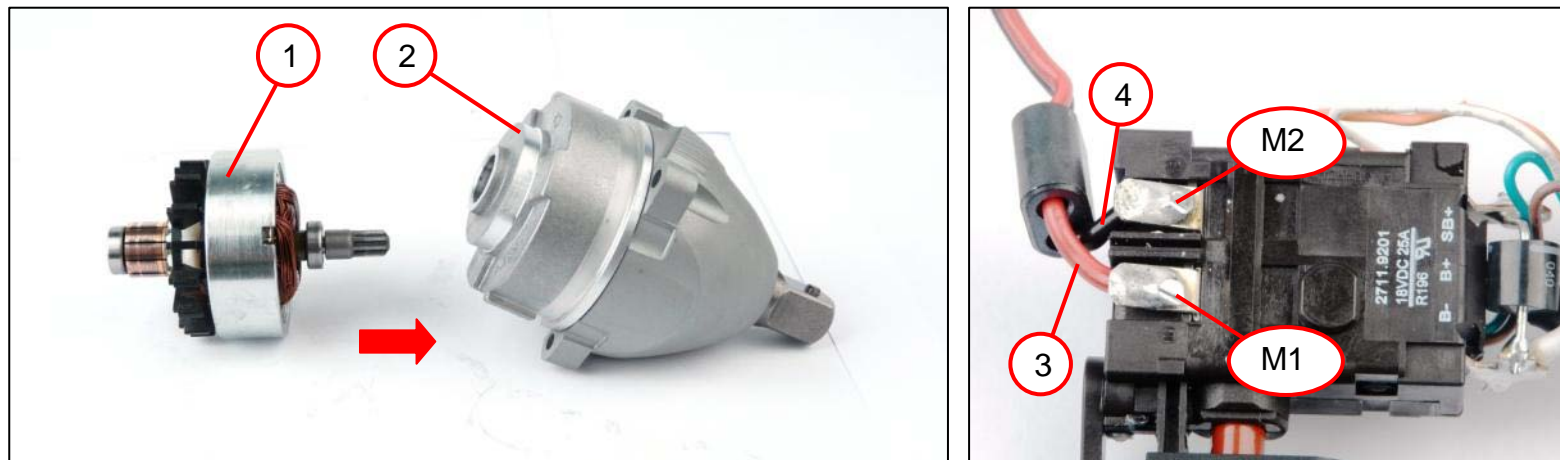

1. Slide armature (1) into gearbox (2).
2. Solder red cable (3) of brush holder set on to position M1 on switch.
3. Solder black cable (4) of brush holder set on to position M2 on switch.

Tool:

- Soldering rod



7. Assembly

Assembling brush holder set

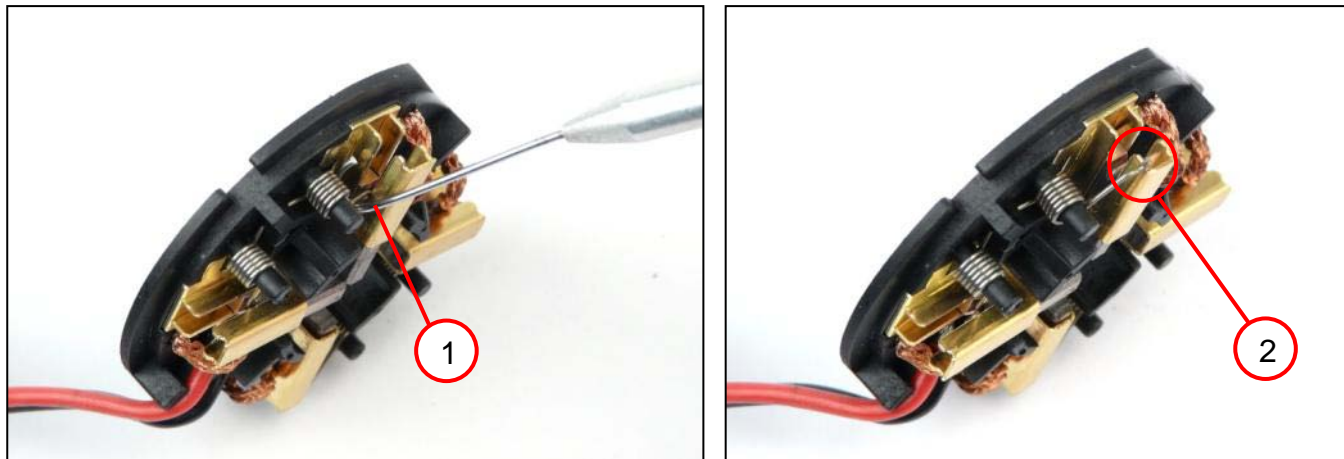

1. Lift the four tension springs (1) of brush holder on to notches provided (2) with hook.

Tool:
- Assembly aid



7. Assembly

Assembling brush holder set

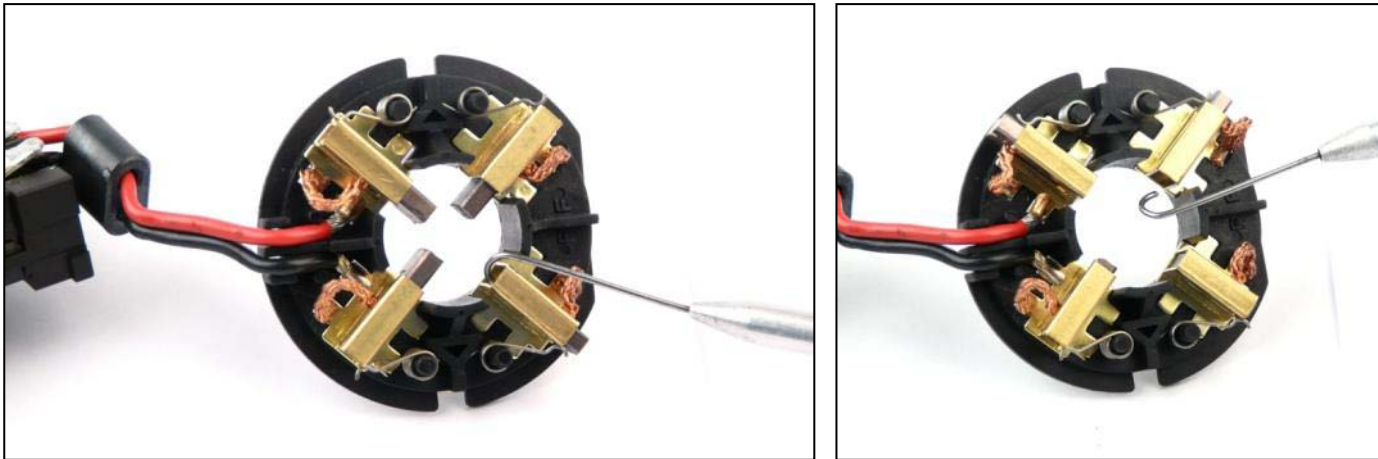

1. Push brushes to the outside to free up the passage.

Tool:

- Assembly aid



7. Assembly

Assembling gearbox

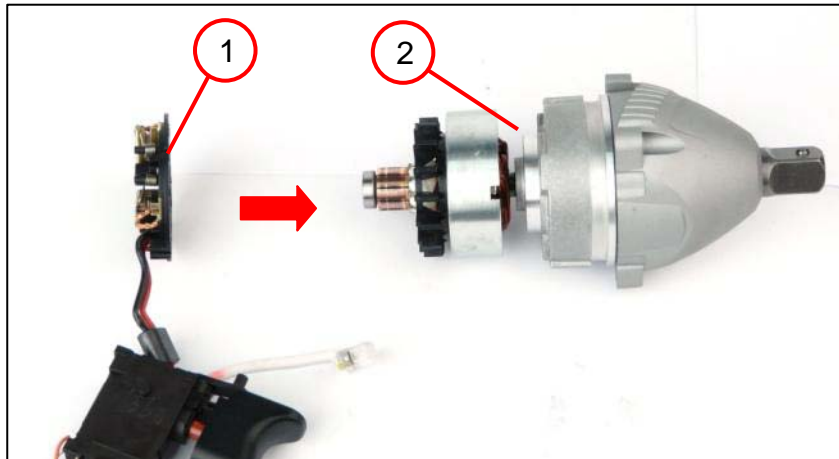

1. Position brush holder set (1) on armature (2).



7. Assembly

Assembling motor

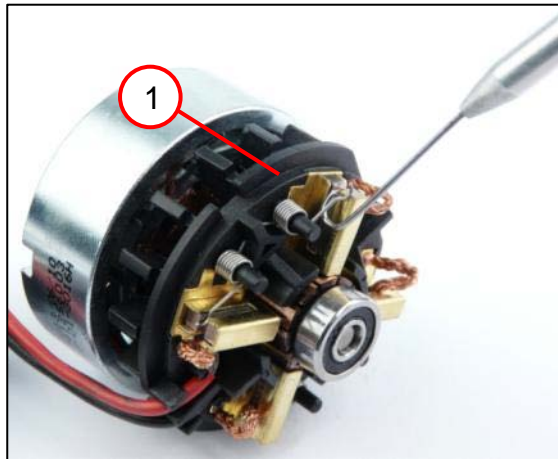

1. Lift the four tension springs (1) of brush holder set back on to carbon brushes with hook.

Tool:

- Assembly aid



7. Assembly

Assembling motor housing

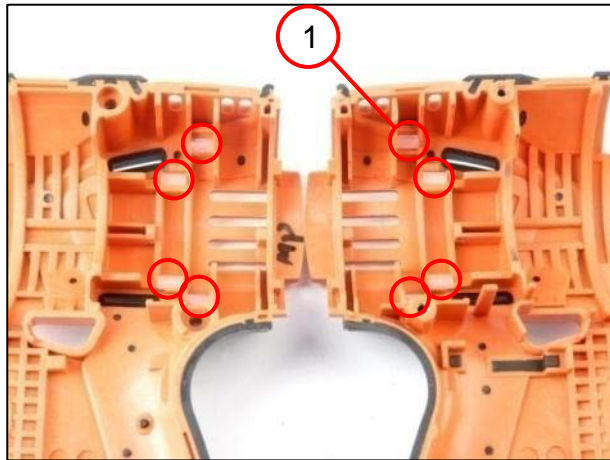

1. Fit the eight pressure pieces (1) in motor housing.



7. Assembly

Assembling motor housing

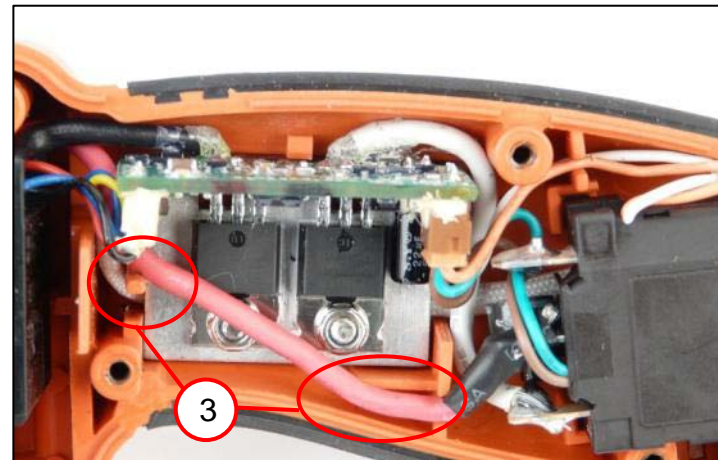
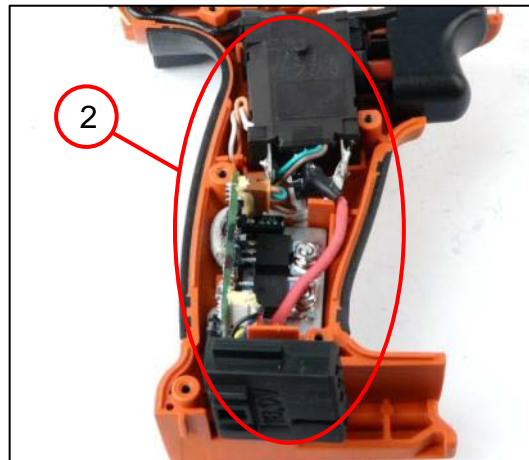
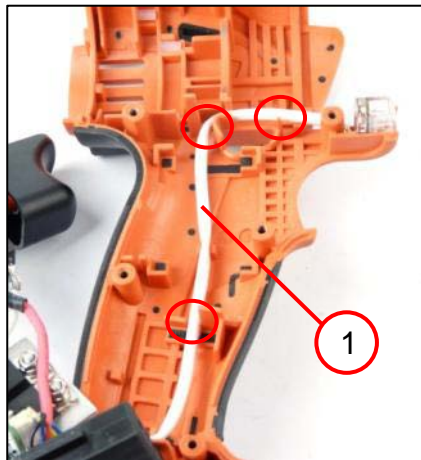

1. Route white cable (1) in grooves provided in motor housing.
2. Insert switch (2) into motor housing half.
☞ Note cable routing (3).

7. Assembly

Assembling motor housing

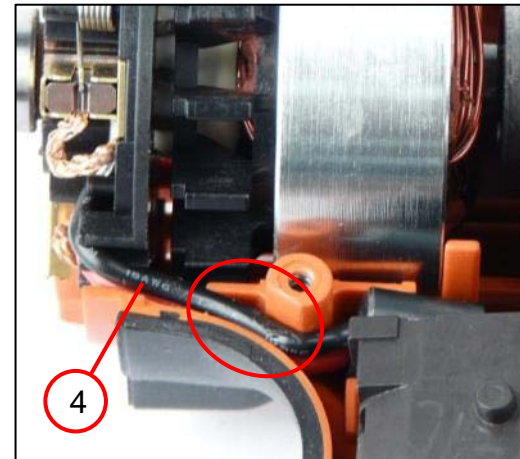
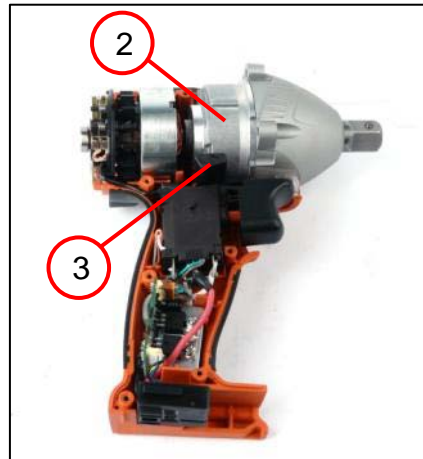
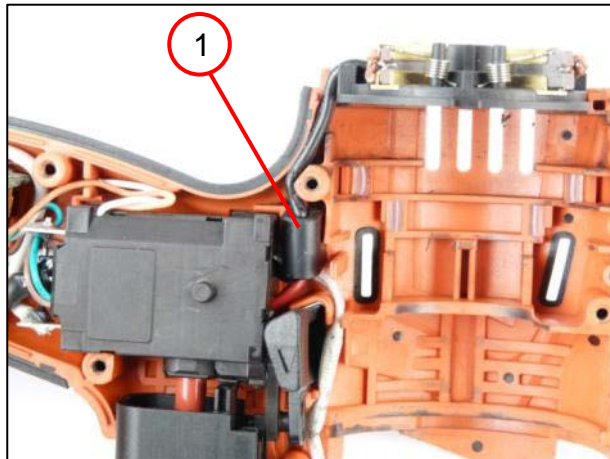

1. Place ferrite ring (1) in the correct position.
2. Insert the gearbox (2) and toggle switch (3) in the motor housing half.
3. Route the cable (4) as shown.



7. Assembly

Assembling motor

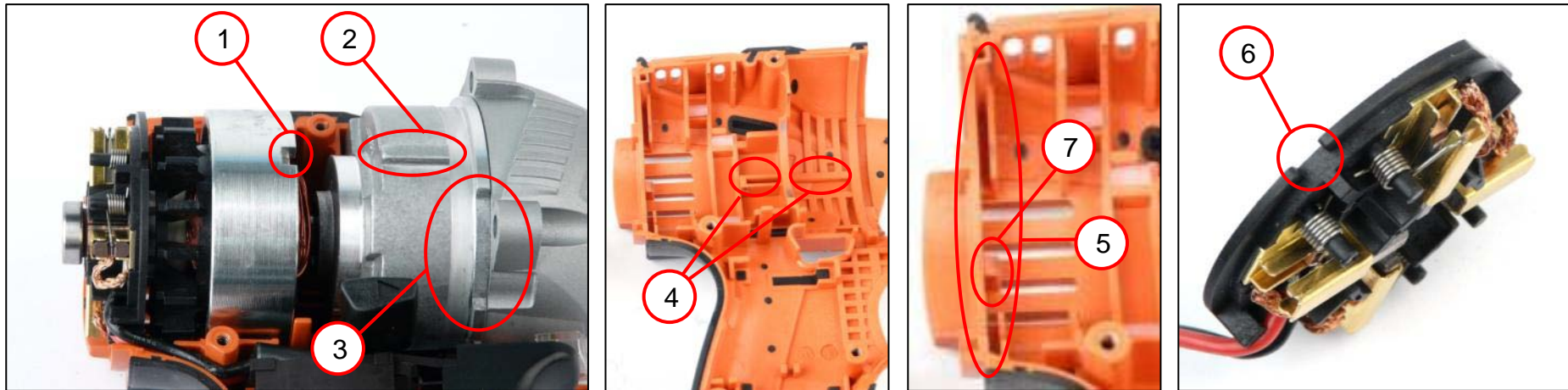

1. Recess (1) on stator and raised section of gearbox (2) must engage in lower half of motor housing (4).
 - ☞ Important: Note position (3) of gearbox groove.
 - ☞ Important: Brush holder set must be inserted into recess (5).
 - ☞ Important: Groove (6) of brush holder set must be inserted above raised section of housing (7).



7. Assembly

Assembling motor housing



1. Screw down motor housing half (1) with seven screws [0.7 Nm – 1.1 Nm].

Tool:

- Torx T10
- Torque wrench



7. Assembly

Assembling housing



1. Screw down gearbox housing with four screws (1) [1.3 Nm \pm 0.4 Nm].
2. Fit cover (2) and screw down with four screws (3) [0.5 Nm – 0.8 Nm].

Tool:

- Cross-tip screwdriver
- Torx T10
- Torque wrench



7. Assembly

Disassembling tool holder (applies to: ASCD 18-W4)



1. Slide sleeve (1) on to tool holder.
2. Slide spring (2) on to tool holder.
3. Position disc (3) on spring.
4. Position circlip (4) and press in.

Tool:

- Sleeve and taper



7. Assembly

Assembling battery



1. Slide battery (1) on to tool.

NOTE

If the tool does not start up during the function test, there is a risk that the battery will be overloaded and destroyed (short-circuit) because the motor is blocked by incorrect installation!

8. Troubleshooting





9. Connection diagram